

Draining and shower systems

The Special Profiles program for drainage systems allows you to solve the most different situations.

Simple and economical drainage wells for laundries or service areas.

Water drainage systems for showers, with square or rectangular shapes, with multiple sizes available. The systems can be used with the supplied grids, with a modern and captivating design, or with the tile holder system, for a “concealed” system.

All our drainage systems are 100% guaranteed for strength, functionality and durability.

All our products are equipped with mats / insulation membranes, accessories for cleaning the system and all are equipped with a siphon.

Easy to install and maintain, sturdy for an excellent long-lasting result.

- Material: Aisi 304 steel - ABS
- Glossy finish
- Dimensions: as per technical data sheets
- Quantity per pack: as per technical data sheets



**SPECIAL
PROFILES**

Sistemi di drenaggio
Draining and shower systems

SPECIALDRAIN	Dimensioni Size	Cod. Art./Item Code	E/pz	Quantità per conf. Packing Quantity
	mm			pz/pcs

ACCIAIO STEEL

100x100	SPCD1010IL00	12,6	16
---------	--------------	------	----

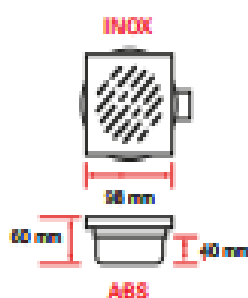

CHUSINO 10x10 REGOLABILE CON GRIGLIA INOX
Corpo e sifone in ABS, Griglia in acciaio inox.

ADJUSTABLE 10x10 FLOOR DRAIN WITH INOX GRATING
Body and siphon in ABS - Grating in stainless steel Aisi 304



SPECIALDRAIN	Dimensioni Size	Cod. Art./Item Code	E/pz	Quantità per conf. Packing Quantity
ACCIAIO STEEL	mm			pz/pcs

ACCIAIO STEEL

130x130	SPCD1313IL00	36,85	12
---------	--------------	-------	----

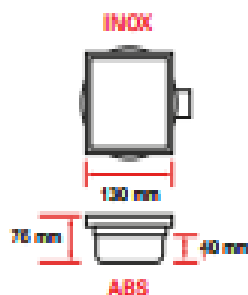

CHUSINO REGOLABILE CON PORTAPIASTRELLA INOX
Acciaio 130x130

ADJUSTABLE INOX FLOOR DRAIN
with tile tray 130x130



SPECIALDRAIN	Dimensioni Size	Cod. Art./Item Code	E/pz	Quantità per conf. Packing Quantity
ABS ABS	mm			pz/pcs

ABS ABS

130x130	SPCD1313PV00	9,6	20
---------	--------------	-----	----

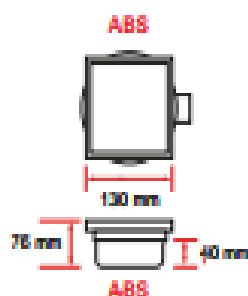

CHUSINO REGOLABILE CON PORTAPIASTRELLA ABS
ABS 130x130

ADJUSTABLE ABS FLOOR DRAIN
with tile tray 130x130



Dimensioni Size	Portata Water flow			Quantità per conf. Packing Quantity
mm	lpm	Cod. Art./Item Code	€/pz	pz/pcs

SPECIALDRAIN	100x100	200	SPCD1010ILOG	115,5	1
ACERO ACIER					

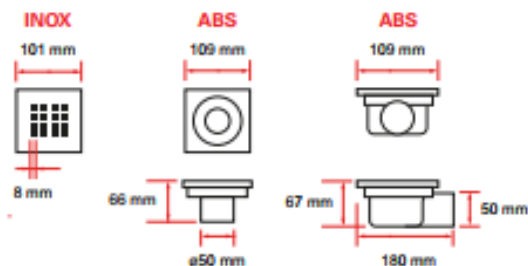

Chiavetta per la rimozione della griglia inclusa
Key for removing the grille included



Filtro rimovibile
Removable filter



Uscita ø80
80 outlet

CHIUSINO 10x10 PER DOCCIA INOX

Griglia 16 fori, vaschetta e corpo sifonato

SHOWER DRAIN 10x10 INOX

16 holes grid, drain body and siphon body

Il kit comprende il corpo sifonato, il foglio di guaina impermeabilizzante con adattatore incorporato, la vaschetta, il filtro e la griglia.

Materiale:

- Vaschetta in PVC
- Corpo sifonato e filtro in ABS
- Griglia e cornice della vaschetta in Acciaio INOX

The kit includes the siphon body, the waterproofing sheet with built-in adapter, the drain body, the filter and the grid.

Materiale:

- Drain body, adapter and filter in ABS.
- Grid and body frame in stainless steel AISI 304.
- Waterproofing sheet composed of two external layers of polypropylene + an inner layer of polyethylene.

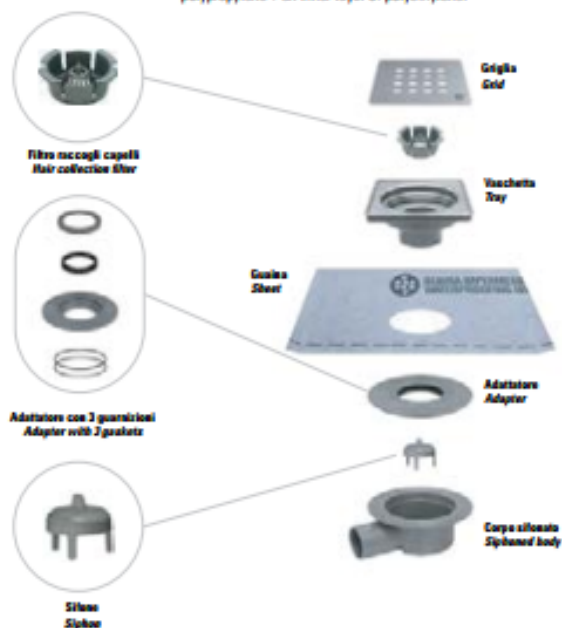

Dimensioni Size	Portata Water flow			Quantità per conf. Packing Quantity
mm	lpm	Cod. Art./Item Code	€/pz	pz/pcs

SPECIALLINEARG				
ACERO ACIER	656x52	200	SPCL0065ILOG	198
				1

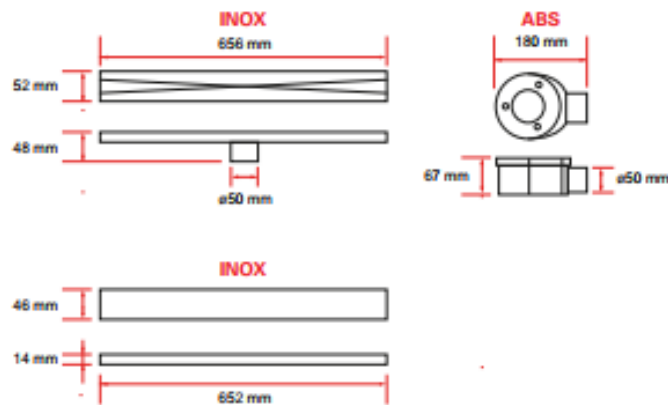

CANALETTA PER DOCCIA CON GRIGLIA INOX LINEAR SHOWER DRAIN WITH INOX GRATING

Il Kit comprende il corpo sifonato, il foglio di guaina impermeabilizzante con adattatore incorporato, la vaschetta, il filtro e la griglia.

Materiale:

- Vaschetta in PVC
- Corpo sifonato e filtro in ABS
- Griglia e cornice della vaschetta in Acciaio INOX
- Waterproofing sheet composed of two external layers of polypropylene + an inner layer of polyethylene.

The kit includes the siphon body, the waterproofing sheet with built-in adapter, the drain body, the filter and the grid.

Material:

- Drain body, adapter and filter in ABS.
- Grid and body frame in stainless steel AISI 304.
- Waterproofing sheet composed of two external layers of polypropylene + an inner layer of polyethylene.



Chiavetta per la rimozione
della griglia inclusa
Key for grille removal included



Filtro rimovibile
Removable filter



Uscita ø50
50W outlet



Disponibili anche le lunghezze 550 mm e 750 mm
Other length available 550 mm e 750 mm

Dimensioni Size	Portata Water flow			Quantità per conf. Packing Quantity
mm	lpm	Cod. Art./Item Code	€/pz	pz/pcs

SPECIALLINEARG ACCIAIO STEEL	658x53	200	SPCLA065ILOG	90,75	1
---	--------	-----	--------------	-------	---

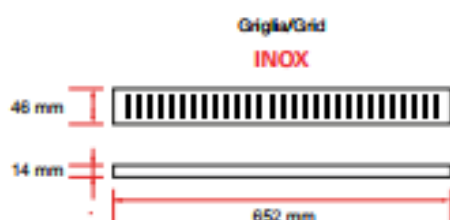
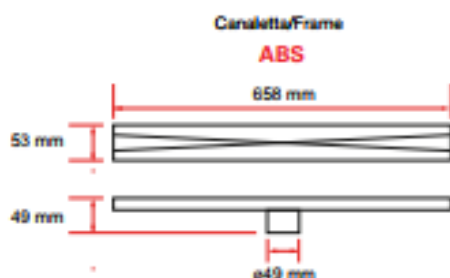

CANALETTA PER DOCCIA CON GRIGLIA INOX
LINEAR SHOWER DRAIN WITH INOX GRATING

Il Kit comprende il corpo sifonato, il foglio di guaina impermeabilizzante con adattatore incorporato, la vaschetta, il filtro e la griglia.

Materiale:

- Vaschetta in PVC
- Corpo sifonato, canaletta e filtro in ABS
- Griglia INOX
- Waterproofing sheet composed of two external layers of polypropylene + an inner layer of polyethylene.

The kit includes the siphoned body, the waterproofing sheet with builtin adapter, the drain body, the filter and the grid.

Material:

- Drain body, frame adapter and filter in ABS
- Grid in stainless steel AISI 304
- Waterproofing sheet composed of two external layers of polypropylene + an inner layer of polyethylene.



Chiavetta per la rimozione della griglia inclusa
Key for grille removal included



Filtro rimovibile
Removable filter



Uscita ø50
50mm outer



Dimensioni Size	Portata Water flow			Quantità per conf. Packing Quantity
mm	lpm	Cod. Art./Item Code	€/pz	pz/pcs

SPECIALLINEARPG	656x52	200	SPCL0065ILPG	206	1
ACCIAIO STEEL					

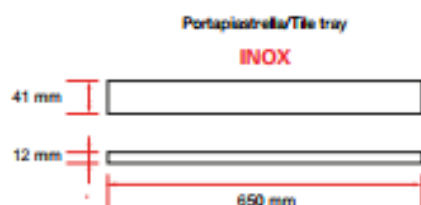
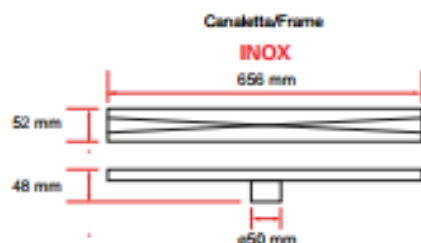

CANALETTA PER DOCCIA CON PORTAPIASTRELLE INOX
LINEAR SHOWER DRAIN WITH INOX TILE TRAY

Il Kit comprende il corpo sifonato, il foglio di guaina impermeabilizzante con adattatore incorporato, la vaschetta, il filtro e il portapiastrella.

Materiale:

- Corpo sifonato e filtro in ABS
- Canaletta e portapiastrella in Acciaio INOX

The kit includes the siphon body, the waterproofing sheet with built-in adapter, the drain body, the filter and the tile tray.

Material:

- Drain body, adapter and filter in ABS.
- Tile tray and body frame in stainless steel AISI 304.
- Waterproofing sheet composed of two external layers of polypropylene + an inner layer of polyethylene.



Filtro rimovibile
Removable filter



Uscita ø50
50 outlet



Il porta piastrella è dotato di fermi in gomma
The tile holder is equipped with rubber stops



	Dimensioni Size	Portata Water flow			Quantità per conf. Packing Quantity
SPECIALLINEARPG	mm	lpm	Cod. Art./Item Code	€/pz	pz/pcs
ACCIAIO STEEL	658x53	200	SPCLA065ILPG	101,75	1

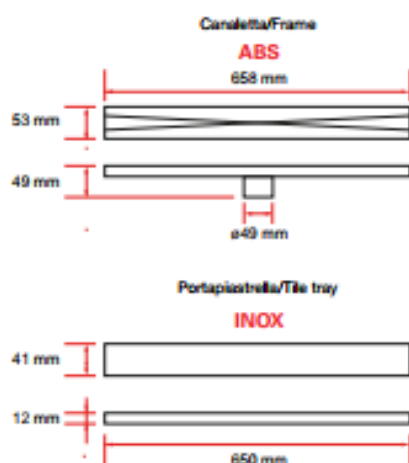

**CANALETTA PER DOCCIA CON PORTAPIASTRELLA INOX
LINEAR SHOWER DRAIN WITH INOX TILE TRAY**

Il Kit comprende il corpo sifonato, il foglio di guaina impermeabilizzante con adattatore incorporato, la vaschetta, il filtro e il portapiastrella.

Materiale:

- Corpo sifonato, canaletta e filtro in ABS
- Portapiastrella in INOX

The kit includes the siphon body, the waterproofing sheet with built-in adaptor, the drain body, the filter and the tile tray.

Material:

- Drain body, adaptor frame and filter in ABS.
- Tile tray in stainless steel AISI 304.

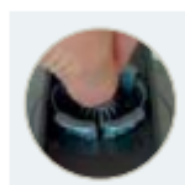

Filtro rimovibile
Removable filter



Uscita ø50
50 outlet

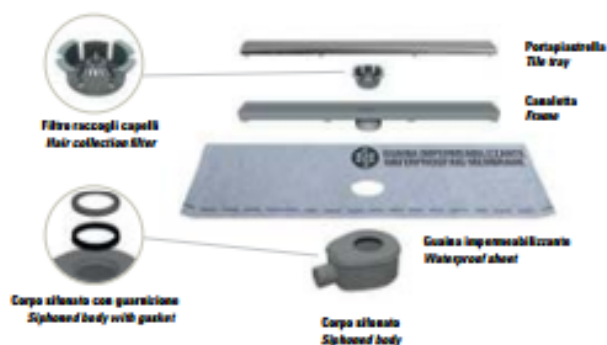

	Dimensioni Size	Densità Density	m ² x rotolo m ² x roll		rotolo roll	Quantità per conf. Packing Quantity
WATERPROOF LAYER	m	g/m ²	m ²	Cod. Art./Item Code	€	pz/pcs
GUAINA SHEATH	1,2x5	300	6	SPMEM5012ROLL	20	1

MATERIALE:

Guaina composta da due strati di poliolefine EVAC + uno strato di fibra di PP.

MATERIAL:

Membrane composed of two layers of EVAC + a layer of PP fibre.



Imballo
Packing



Main characteristics of the raw materials used by Special Profiles

ALUMINUM

Aluminum alloy (Al-Mg-Si) The profiles are made by extrusion or lamination and subsequent press bending. They have excellent resistance to the main chemical and atmospheric agents. Surface treatments through the company's proprietary systems, transform the material into:

Anodized aluminum: anodic oxidation with 8-10 microns of oxide thickness.

Polished Aluminum: anodic oxidation with 8-10 microns of oxide thickness.

Painted Aluminum: powder coated, with about 100 microns of paint thickness.

Not recommended for floor use.

STAINLESS STEEL - AISI 304

The profiles are made by rolling and subsequent press bending. They have excellent resistance to the main chemical and atmospheric agents and excellent mechanical resistance

Surface treatments through the company's systems, transform the material into:

Polished and bright steel. Use both on the wall and on the floor, in hospitals, food, industry.

- Attention: the cutting edges are not stainless

Rigid PVC (Corner protectors)

Lead-free, impact-resistant, self-extinguishing rigid vinyl chloride. Good mechanical and abrasion resistance.

Co-extruded PVC - Rigid / Soft (expansion joints)

Co-extruded rigid vinyl chloride with soft PVC, leadfree, shockproof, self-extinguishing. Excellent mechanical resistance, to abrasion.

PE-HD (Tile spacers)

High density polyethylene, thermoplastic resin, excellent chemical stability and mechanical resistance. The high density (HD) increases its stiffness.

POLYPROPYLENE (External square and round corners)

Thermoplastic polymer, semi-crystalline, with good mechanical and abrasion resistance.

Maintenance

Avoid direct contact with concrete and its derivatives, if wet, descaling products and detergents that contain chlorine. Avoid using abrasive products that can scratch (abrasive sponges / metal wool). Immediately after laying proceed with a thorough cleaning of the surfaces with plenty of water / neutral / non-alkaline PH products, in particular remove cement, glue from the exposed surfaces.

Measures and tolerances

All information and drawings contained in this catalog are non-binding and subject to change without notice.

All dimensional data refer to nominal dimensions, subject to mechanical tolerances, according to the En- 22768 ISO-2768 -m standard.

Special Profiles codes/Descriptions

Raw Material

A= Aluminium
Z=Zincked

F= Iron

P= PVC

I= Steel

O= Brass

Colours

A=Silver B=Light Brown

O=Gold M=Brown

N=Black

B=White

G=Gray

Surface treatments

N=Natural

A=Anodized

V=Painted

P=Brushed

B=Brilliant

L=Bright

O=Matt

S=SuperBright



Special
Mecc.Al Group



Profiles a brand of



- Via dei Laghi, 4 - Calcinelli 61036 Colli al Metauro (PU) - Italia Tel. +39.0721.8764.163

**Website : www.special-profiles.com e-mail:
specialprofiles@meccal.com**